

SPECIFICATIONS

BETWEEN FRAME RAILS	6" TO 48"
ROLL CONSTRUCTION	ROUND TUBE, 1.9" DIAMETER, 16 GAUGE
BEARING TYPE	SEMI-PRECISION, ZINC PLATED STEEL HOUSING, OILED, 7/16" HEX
AXLE RETENTION	STANDARD – SPRING LOADED ONE SIDE. OPTIONAL: COTTER PIN, FIXED PIN, LOOSE BOLT OR FIXED AXLE
ROLLER SURFACE	STANDARD GALVANIZED STEEL

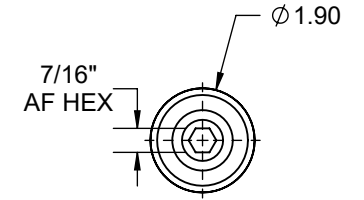

**BEARING CROSS SECTION
DETAILED VIEW**

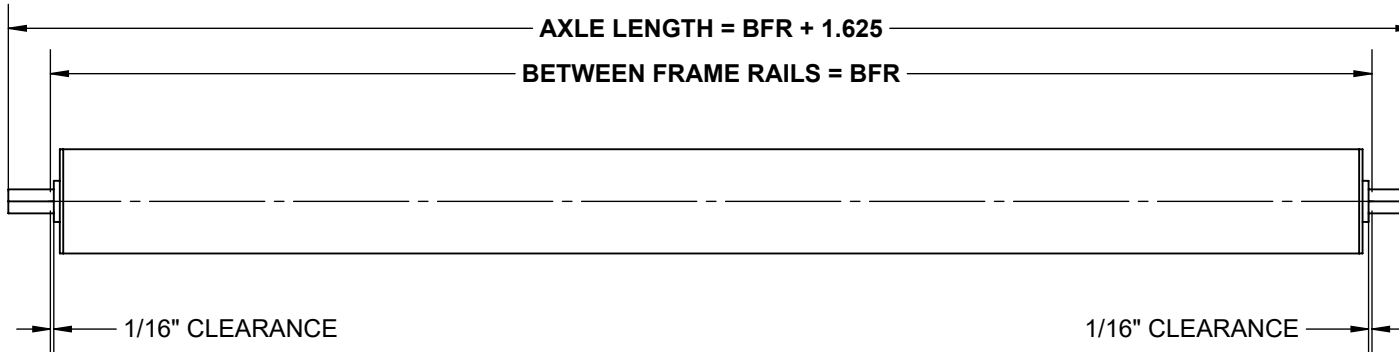
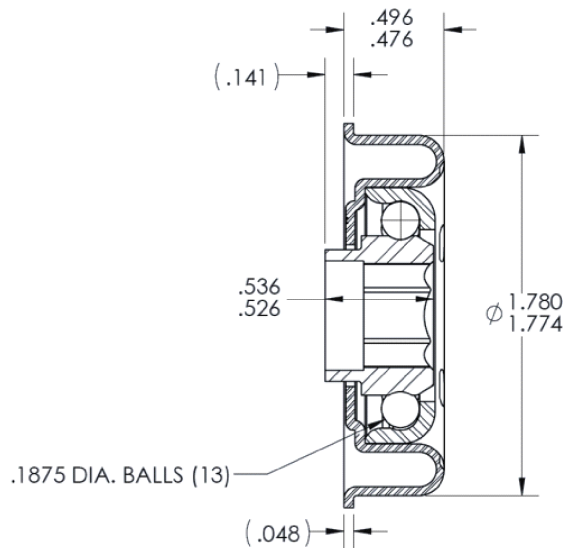

RM-1805
 LUBRICATION TYPE: OIL
 LOAD RATING: 300 lbs.
 TEMP. RATING: -10F to 400F
 NOISE LEVEL: QUIET
 PROTECTION: FRONT INTEGRAL SHIELD

**STANDARD ROLLER
CAPACITY CHART**

BFR [IN]	LOAD CAPACITY [LBS.]
6	540
9	
12	
15	467
18	384
21	326
24	283
27	251
30	225
33	203
36	186
39	171
42	159
45	148
48	138

REV

0

Model: 1916, 1.9" Dia. - 16 Ga. Roller

