

SPECIFICATIONS	
BETWEEN FRAME RAILS	4" TO 72"
ROLL CONSTRUCTION	STRUCTURAL ROUND TUBE, 3 1/2" DIAMETER, 1/4" WALL THICKNESS
BEARING TYPE	NON-PRECISION, ZINC PLATED STEEL, GREASED, 1 1/16" HEX
AXLE RETENTION	STANDARD - COTTER PIN. OPTIONAL: LOOSE BOLT
ROLLER SURFACE	STANDARD CARBON STEEL.

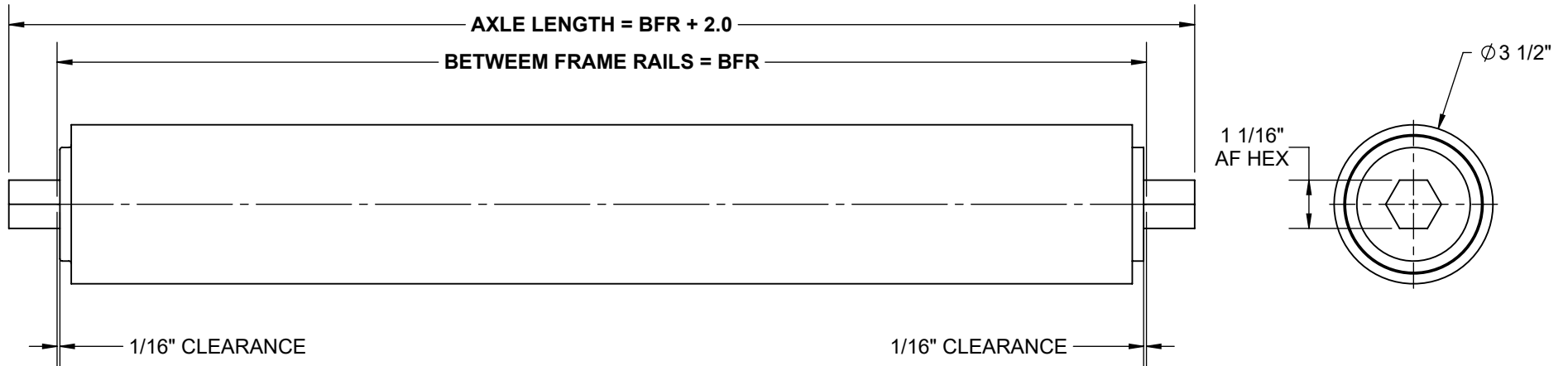

BEARING CROSS SECTION
DETAILED VIEW

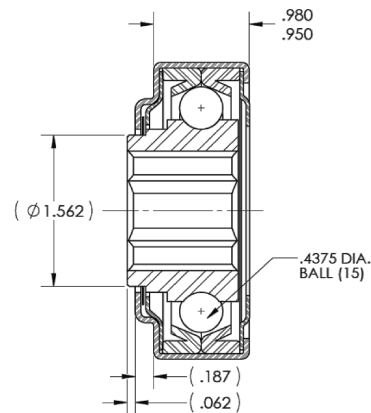

RM-3082
LUBRICATION TYPE: GREASE
LOAD RATING: 603 lbs.
TEMP. RATING: -20F to 150F

STANDARD ROLLER CAPACITY CHART	
BFR [IN]	LOAD CAPACITY [LBS.]
4 TO 72	1000

REV	0	Model: 3525, 3 1/2" Dia. - 1/4" Wall Steel Roller
-----	---	--

