

SPECIFICATIONS

BETWEEN FRAME RAILS	6" TO 54"
ROLL CONSTRUCTION	STRUCTURAL ROUND TUBE, 1.9" DIAMETER, 0.145" WALL STEEL
BEARING TYPE	SEMI-PRECISION, CARBON STEEL HOUSING, GREASED, 7/16" HEX
AXLE RETENTION	STANDARD - SPRING LOADED ONE SIDE. OPTIONAL: COTTER PIN OR FIXED AXLE
ROLLER SURFACE	STANDARD CARBON STEEL
STANDARD SPROCKETS	50A18
MINIMUM C-C	5"

AVAILABLE OPTIONAL FEATURES:

1. CUSTOM AXLE EXTENSION FROM BFR
2. CUSTOM SPROCKETS SPACING
3. NON STANDARD SPROCKETS
4. PVC COVER

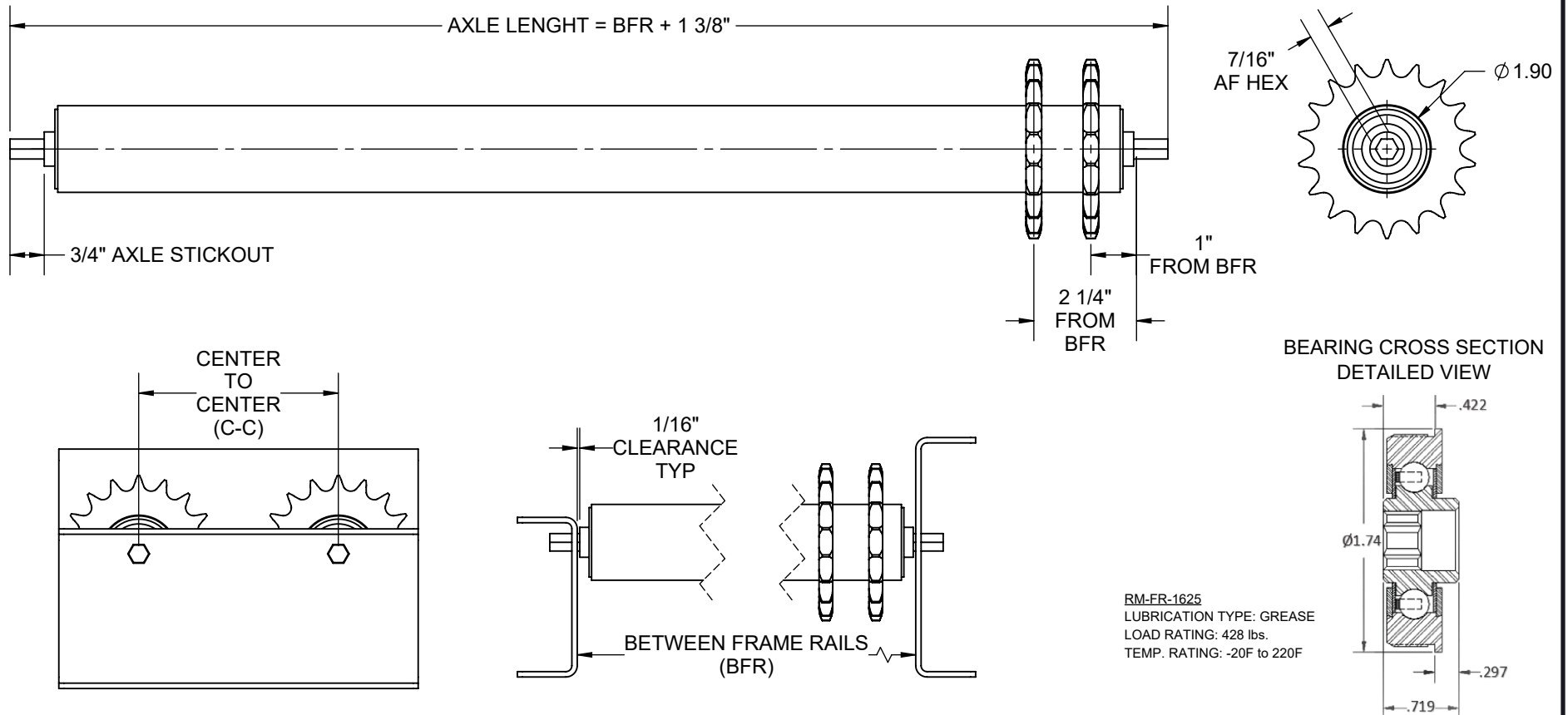

REV

0

Model: CR19145HD - 50A18X1.9

