

MODEL	MIN. HEIGHT	MAX. HEIGHT	RANGE	OVERALL WIDTH
1012	10"	12"	2"	BETWEEN FRAME RAILS + 3"
1215	12"	15"	3"	
1418	14"	18"	4"	
1725	17"	25"	8"	
2436	24"	36"	12"	
3548	35"	48"	13"	
4860	48"	60"	12"	
6072	60"	72"	12"	

REGULAR DUTY SUPPORT WITH FIXED BOOTS

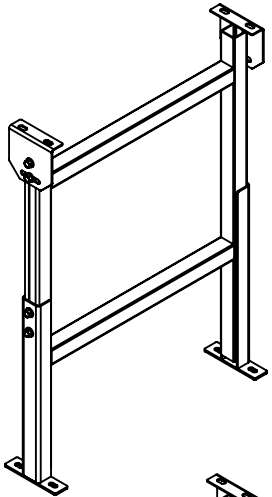

REGULAR DUTY SUPPORT WITH CASTER BOOTS

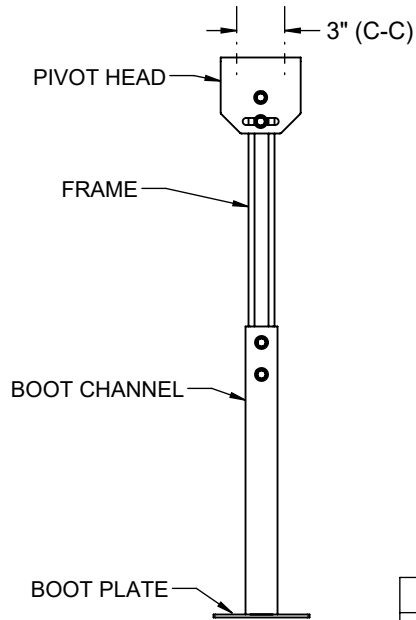
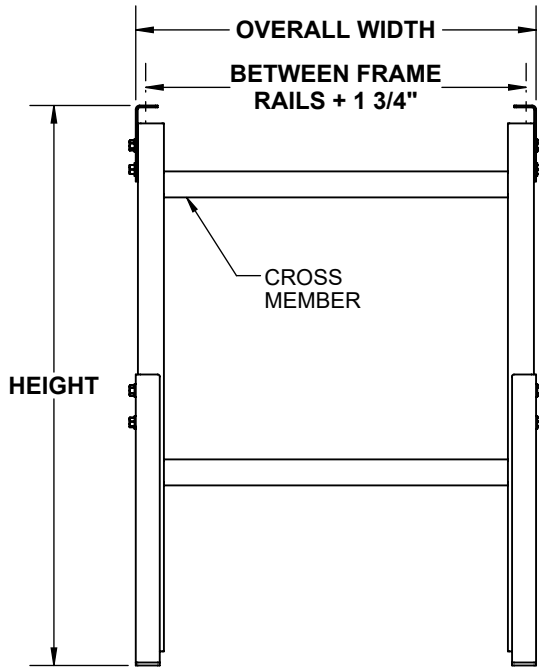
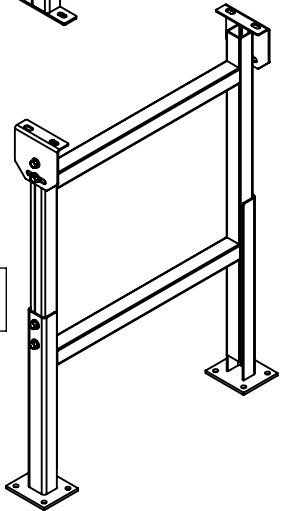

NOTE:  
FOR BOOT PLATE HOLES LOCATION; REFER TO "CASTERS & BOOTS OPTIONS-SR" DRAWING

SPECIFICATIONS	
HEAD PLATE TYPE	PIVOT
BOOT PLATE TYPE	FIXED OR CASTER MOUNTING
BETWEEN FRAME RAILS (BFR)	1 1/2" TO 72"
MATERIAL	PLAIN CARBON STEEL
FINISH	INDUSTRIAL ENAMEL
CAPACITY	1500 LBS.

REV	0	<b>Model: SR, Regular Duty Support (General)</b>
-----	---	--

