

**COTTER PIN SIZES (Dia. x Length):**  
 5/16" HA - 1/8" x 1"  
 7/16" HA - 3/16" x 1 1/2"  
 11/16" HA - 3/16" x 2"  
 1-1/16" HA - 3/16" x 2 1/2"  
 (HA - HEX AXLE )

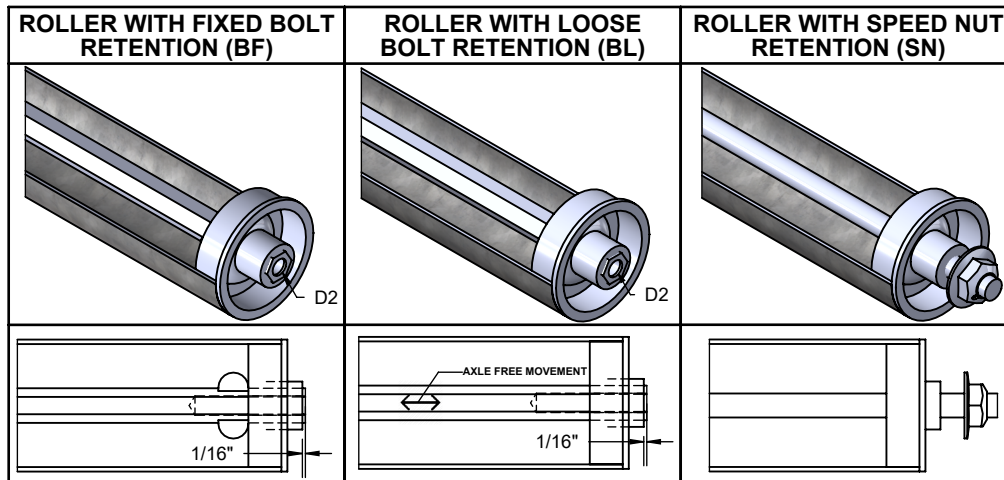



**SERRATED HEX FLANGE BOLT SIZE: (Grade 5 Steel)**  
 5/16" HA - 1/4"-20, 1" Long  
 7/16" HA - 5/16"-18, 1" Long  
 11/16" & 1-1/16" HA - 1/2"-13, 1" Long

**SERRATED HEX FLANGE BOLT SIZE: (Grade 5 Steel)**  
 5/16" HA - 1/4"-20, 1" Long  
 7/16" HA - 5/16"-18, 1" Long  
 11/16" & 1-1/16" HA - 1/2"-13, 1" Long

**SPEED NUT SIZE:**  
 INSIDE DIA. = 1/4"  
 FLANGE DIA. = 11/16"  
 HEX WIDTH = 7/16"

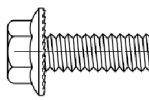
MODEL	HEX AXLE SIZE	CP	SL	BF	F	BL	SN	D1	D2 (UNC)	L1
1418	5/16"	✓	✓	✓	✓	✓	-	1/8"	1/4" - 20 x 1.0"	0.180"
1418HS	5/16"	✓	✓	✓	✓	✓	-	1/8"	1/4" - 20 x 1.0"	0.180"
1418R	-	-	✓	-	✓	-	✓	-	-	-
15065	5/16"	✓	✓	✓	✓	✓	-	1/8"	1/4" - 20 x 1.0"	0.180"
1916	7/16"	✓	✓	✓	✓	✓	-	3/16"	5/16" - 18 x 1.0"	0.253"
1916HS	7/16"	✓	✓	✓	✓	✓	-	3/16"	5/16" - 18 x 1.0"	0.253"
1916P	7/16"	✓	✓	✓	✓	✓	-	3/16"	5/16" - 18 x 1.0"	0.253"
19145	7/16"	✓	✓	✓	✓	✓	-	3/16"	5/16" - 18 x 1.0"	0.253"
19145HD	7/16"	✓	✓	✓	✓	✓	-	3/16"	5/16" - 18 x 1.0"	0.253"
2013	7/16"	✓	✓	✓	✓	✓	-	3/16"	5/16" - 18 x 1.0"	0.253"
2514	7/16"	✓	✓	✓	✓	✓	-	3/16"	5/16" - 18 x 1.0"	0.253"
2514HS	11/16"	✓	✓	✓	✓	✓	-	3/16"	1/2" - 13 x 1.0"	0.397"
2511	11/16"	✓	✓	✓	✓	✓	-	3/16"	1/2" - 13 x 1.0"	0.397"
2511C	11/16"	✓	✓	✓	✓	✓	-	3/16"	1/2" - 13 x 1.0"	0.397"
2925	11/16"	✓	✓	✓	✓	✓	-	3/16"	1/2" - 13 x 1.0"	0.397"
3525	1 1/16"	✓	-	-	-	✓	-	3/16"	1/2" - 13 x 1.0"	0.613"
T16925P	7/16"	✓	✓	✓	✓	✓	-	3/16"	5/16" - 18 x 1.0"	0.253"
T16925	7/16"	✓	✓	✓	✓	✓	-	3/16"	5/16" - 18 x 1.0"	0.253"

HARDWARE		
		
<b>COTTER PIN</b> SUPPLIED WITH CP RETENTION TYPE	<b>SERRATED HEX FLANGE BOLT</b> SUPPLIED WITH BF & BL RETENTION TYPES	<b>SPEED NUT</b> SUPPLIED WITH SN RETENTION TYPE

REV

0

**AVAILABLE AXLE RETENTION TYPES**



▲	GROOVE TYPE										GROOVE DIA.
	A	B	C	D	E	F	G	H	I		
ROLLER MODEL	1418HS	✓	✓	✓	✓	✓	✓	✓	✓	✓	1/8"
	1916HS	✓	✓	✓	✓	✓	✓	✓	✓	✓	3/16"
	2514	✓	✓	✓	✓	✓	✓	✓	✓	✓	1/4"
	2514HS	✓	✓	✓	✓	✓	✓	✓	✓	✓	1/4"
	T16925P	✓	✓	✓	-	-	-	-	-	-	3/16"

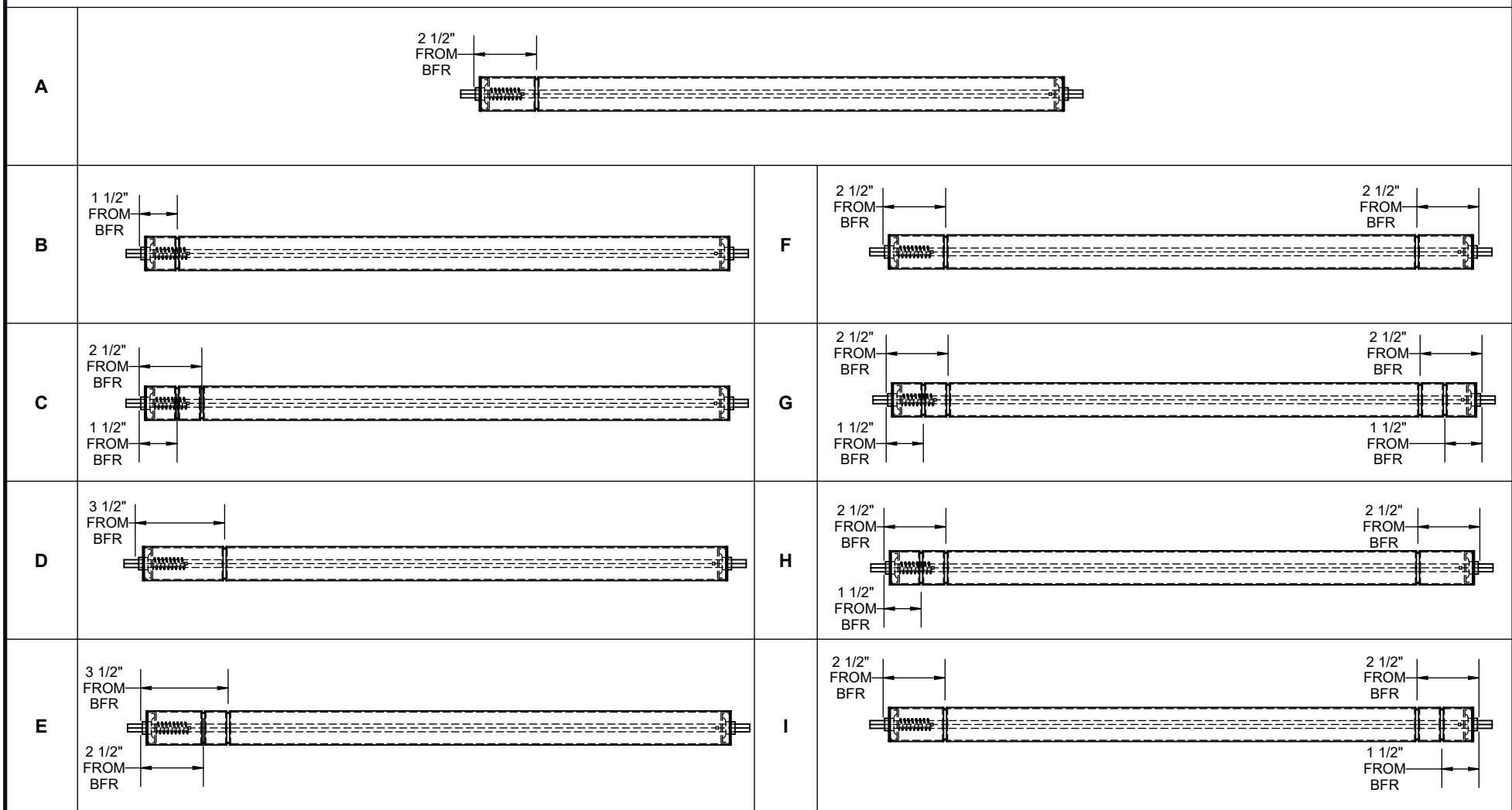

REV	0	<b>AVAILABLE GROOVE TYPES</b>
-----	---	-------------------------------

