

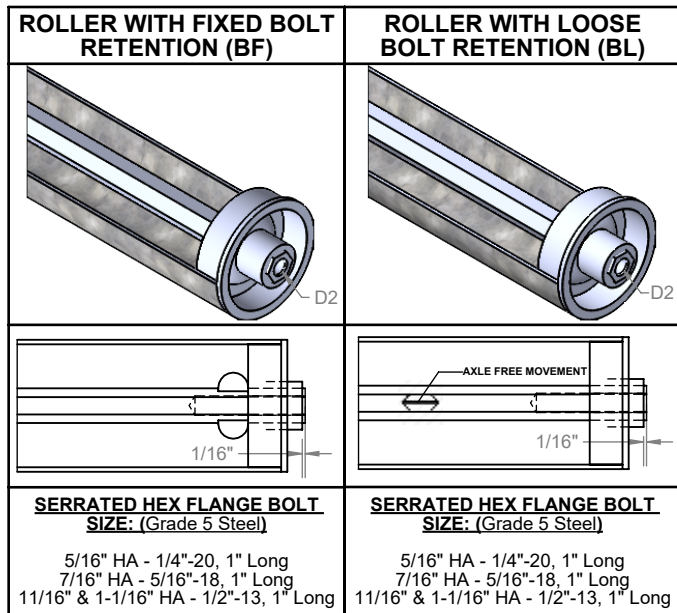

COTTER PIN SIZES (Dia. x Length):

5/16" HEX AXLE - 1/8" x 1"
 7/16" HEX AXLE - 3/16" x 1 1/2"
 11/16" HEX AXLE - 3/16" x 2"
 1-1/16" HEX AXLE - 3/16" x 2 1/2"

MODEL	HEX AXLE SIZE	SL	CP	F	BF	BL	D1	D2 (UNC)	L1
1418	5/16"	✓	✓	✓	✓	✓	1/8"	1/4" - 20 x 1.0"	0.180"
1418HS	5/16"	✓	✓	✓	✓	✓	1/8"	1/4" - 20 x 1.0"	0.180"
15065	5/16"	✓	✓	✓	✓	✓	1/8"	1/4" - 20 x 1.0"	0.180"
1916	7/16"	✓	✓	✓	✓	✓	3/16"	5/16" - 18 x 1.0"	0.253"
1916P	7/16"	✓	✓	✓	✓	✓	3/16"	5/16" - 18 x 1.0"	0.253"
1916HS	7/16"	✓	✓	✓	✓	✓	3/16"	5/16" - 18 x 1.0"	0.253"
1916V	7/16"	✓	-	-	-	-	-	-	-
19145	7/16"	✓	✓	✓	✓	✓	3/16"	5/16" - 18 x 1.0"	0.253"
19145HD	7/16"	✓	✓	✓	✓	✓	3/16"	5/16" - 18 x 1.0"	0.253"
2013	7/16"	✓	✓	✓	✓	✓	3/16"	5/16" - 18 x 1.0"	0.253"
2514	7/16"	✓	✓	✓	✓	✓	3/16"	5/16" - 18 x 1.0"	0.253"
2514HS	11/16"	✓	✓	✓	✓	✓	3/16"	1/2" - 13 x 1.0"	0.397"
2511	11/16"	✓	✓	✓	✓	✓	3/16"	1/2" - 13 x 1.0"	0.397"
2511C	11/16"	✓	✓	✓	✓	✓	3/16"	1/2" - 13 x 1.0"	0.397"
2511MG	11/16"	✓	✓	✓	✓	✓	3/16"	1/2" - 13 x 1.0"	0.397"
2925	11/16"	✓	✓	✓	✓	✓	3/16"	1/2" - 13 x 1.0"	0.397"
3525	1 1/16"	-	✓	-	-	✓	3/16"	1/2" - 13 x 1.0"	0.613"

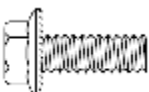

HARDWARE	
	
<p>COTTER PIN SUPPLIED WITH CP RETENTION TYPE</p>	<p>SERRATED HEX FLANGE BOLT SUPPLIED WITH BF & BL RETENTION TYPES</p>