

SPECIFICATIONS	
OVERALL LENGTH	6" TO 120"
OVERALL WIDTH	9" TO 51"
BETWEEN FRAME RAILS	6" TO 48"
BALL CENTERS	2", 3", 4", 6"
BALL PATTERN	STRAIGHT, OPTIONAL STAGGERED
BALL TRANSFER	1" DIA CARBON STEEL 1/4" - 20 BOLT
SIDE CHANNELS	3 1/2" X 1 1/2" X 10 GA
FRAME MATERIAL	PLAIN STEEL
FINISH	INDUSTRIAL ENAMEL

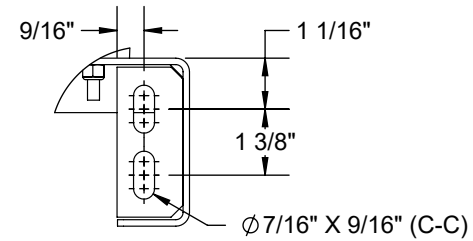

DETAIL A

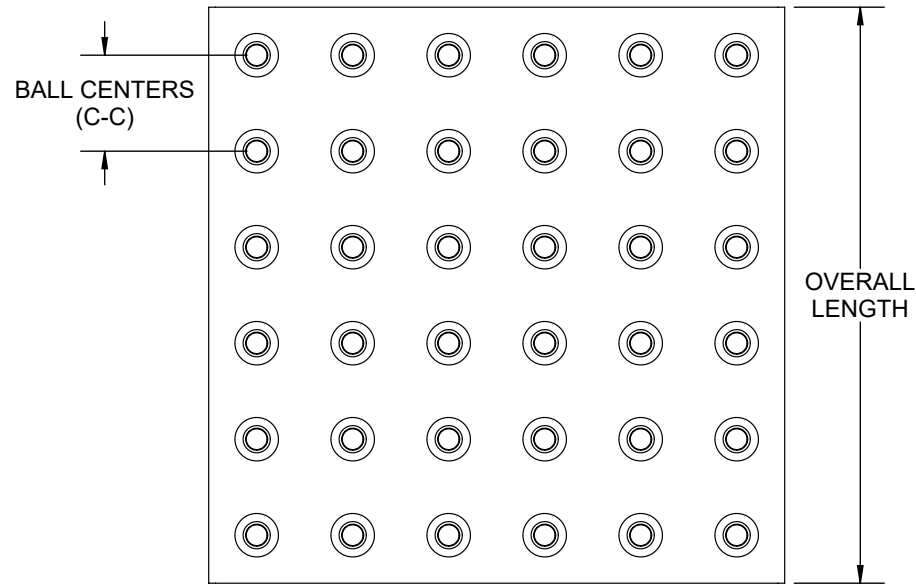
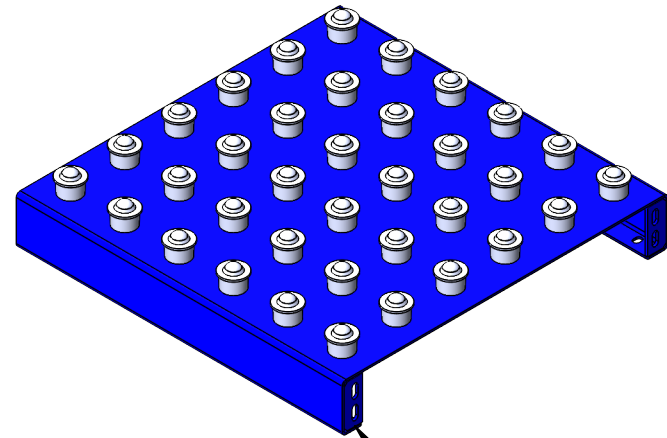
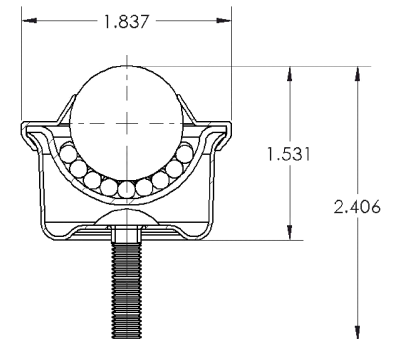
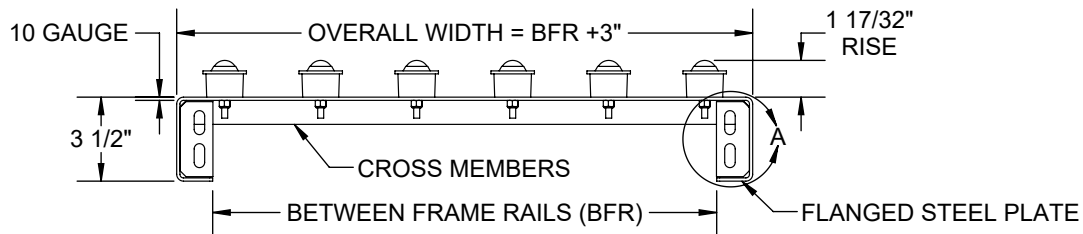

RM-1000
 LUBRICATION TYPE: OIL
 LOAD RATING: 150 LBS.
 TEMP. RATING: UP TO 400F