

SPECIFICATIONS		
OVERALL LENGTH (DRIVE)	40" TO 120"	
OVERALL LENGTH (SLAVE)	18" TO 120"	
OVERALL WIDTH	11" TO 75"	
ROLLER CENTERS (C-C)	4", 4 1/2", 5", 6"	
EFFECTIVE BETWEEN FRAME RAILS	4 1/2" TO 68 1/2"	
LINE SPEED (FPM)	15, 20, 25, 30, 40, 50, 60	
ROLLERS	2 1/2" DIA X 11 GA STEEL - 11/16" HEX AXLE	
BEARINGS	PRECISION, OILED	
SIDE CHANNELS	1	6" X 1 1/2" X 3/16"
	2	4" X 1 1/2" X 3/16"

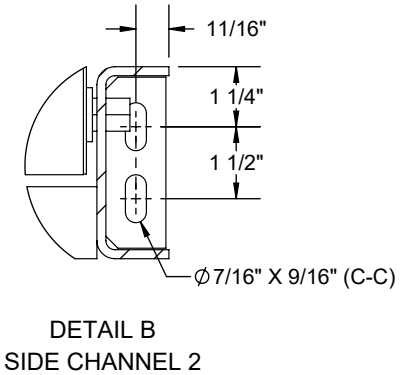

REV	0	Model: CR - 2511 Chain Driven Live Roller Conveyor
-----	---	---

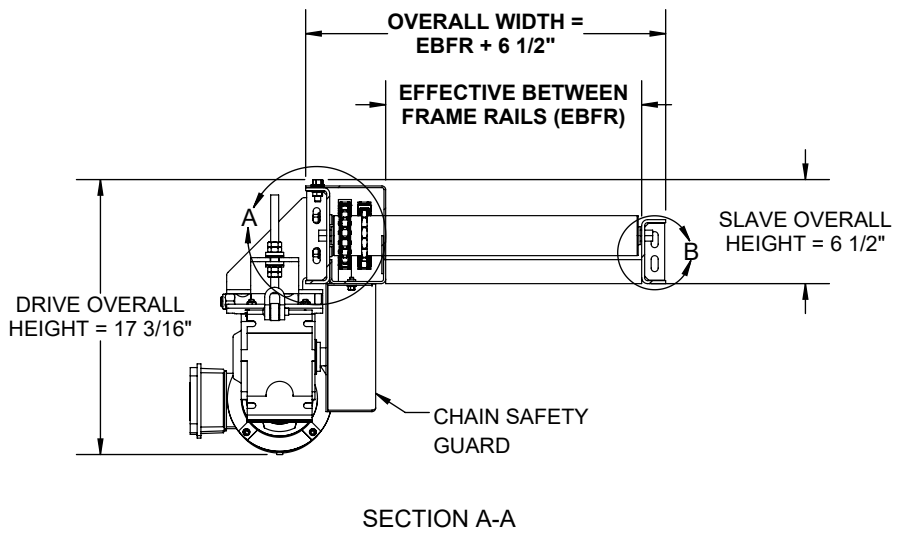
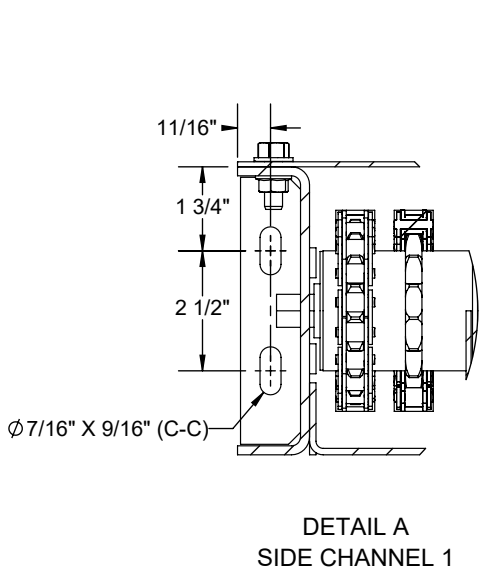
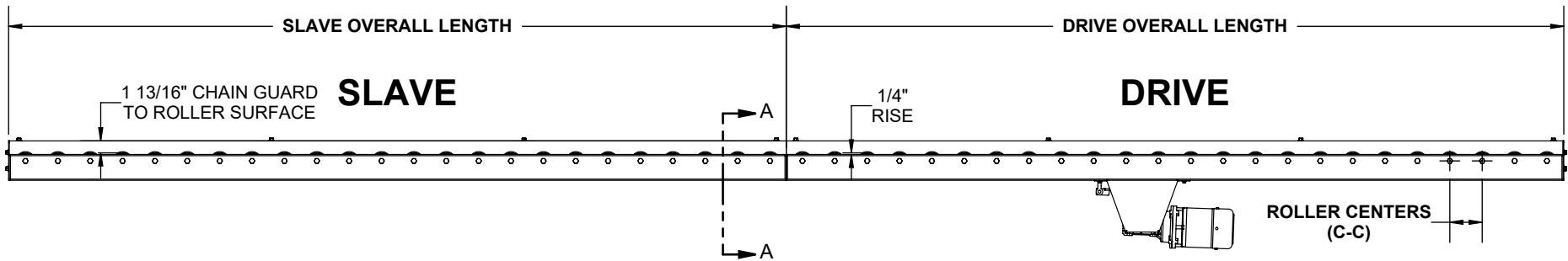
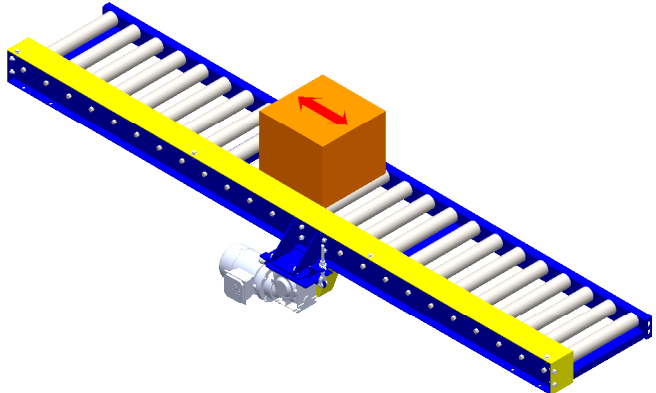

1.0 DRIVE CONVEYOR

FRONT SIDE

BACK SIDE

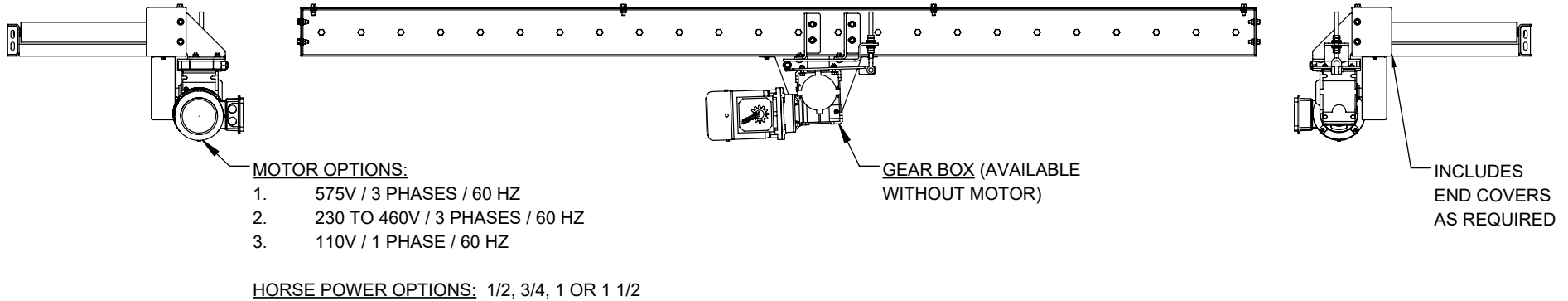

2.0 DRIVE COUPLING

C-C	SPROCKET	CHAIN PITCH
4"	40A21X2.5	0.5
4 1/2"	60A15X2.5	0.75
5"	50A18X2.5	0.625
6"	60A16X2.5	0.75

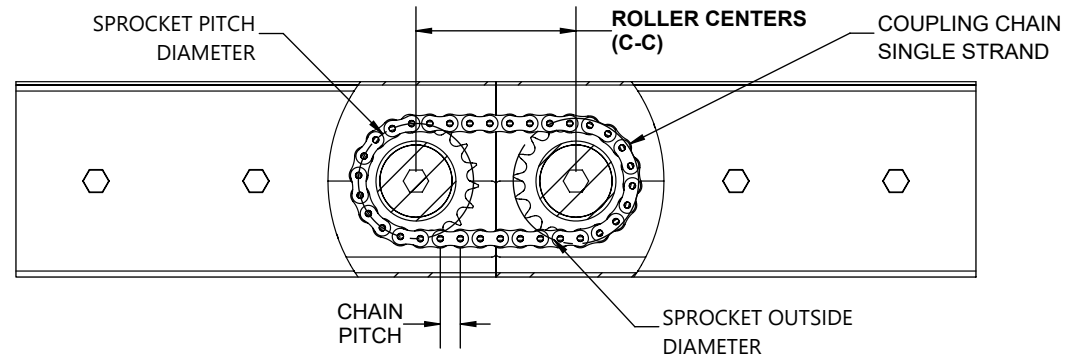

REV

0

Model: CR - 2511 Chain Driven Live Roller Conveyor Info

ROLMASTER
CONVEYORS SINCE 1946

3.0 MOTOR ORIENTATION

NOTE:
FRONT & BACK ORIENTATIONS ARE ONLY
AVAILABLE WHEN OVERALL LENGTH IS MORE
THAN 60"

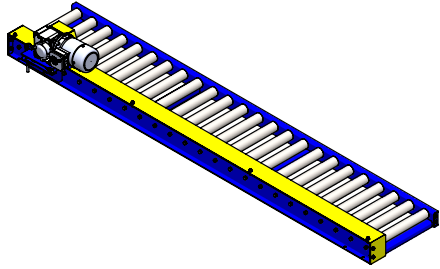

TOP FRONT

FRONT

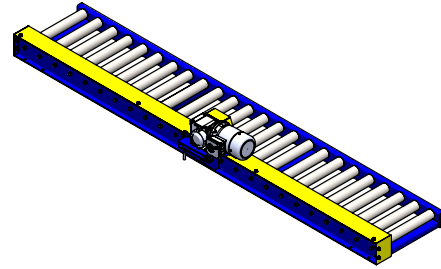

BACK

TOP MIDDLE

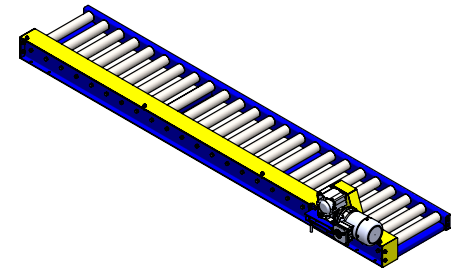

TOP BACK

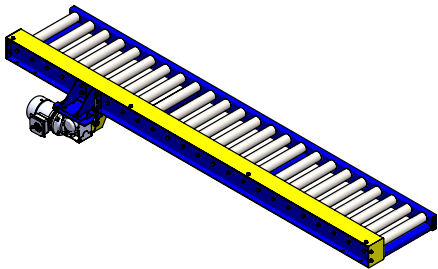

BOTTOM FRONT

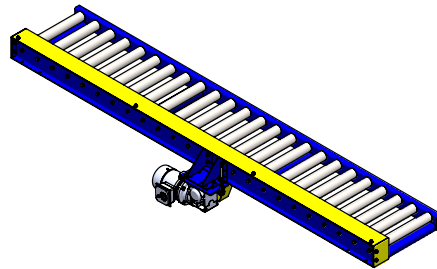

BOTTOM MIDDLE

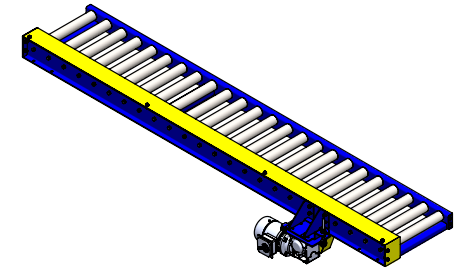

BOTTOM BACK

REV

0

Model: CR - 2511 Chain Driven Live Roller Conveyor Info

