

SPECIFICATIONS

BETWEEN FRAME RAILS	8" TO 72"
ROLL CONSTRUCTION	ROUND TUBE, 2 1/2" DIAMETER, 11 GAUGE
BEARING TYPE	NON-PRECISION, ZINC PLATED STEEL HOUSING, GREASED, 11/16" HEX
AXLE RETENTION	STANDARD - SPRING LOADED ONE SIDE. OPTIONAL: COTTER PIN OR FIXED AXLE
ROLLER SURFACE	STANDARD CARBON STEEL
STANDARD SPROCKETS	60A16
MINIMUM C-C	6"

AVAILABLE OPTIONAL FEATURES:

1. CUSTOM AXLE EXTENSION FROM BFR
2. CUSTOM SPROCKETS SPACING
3. NON STANDARD SPROCKETS

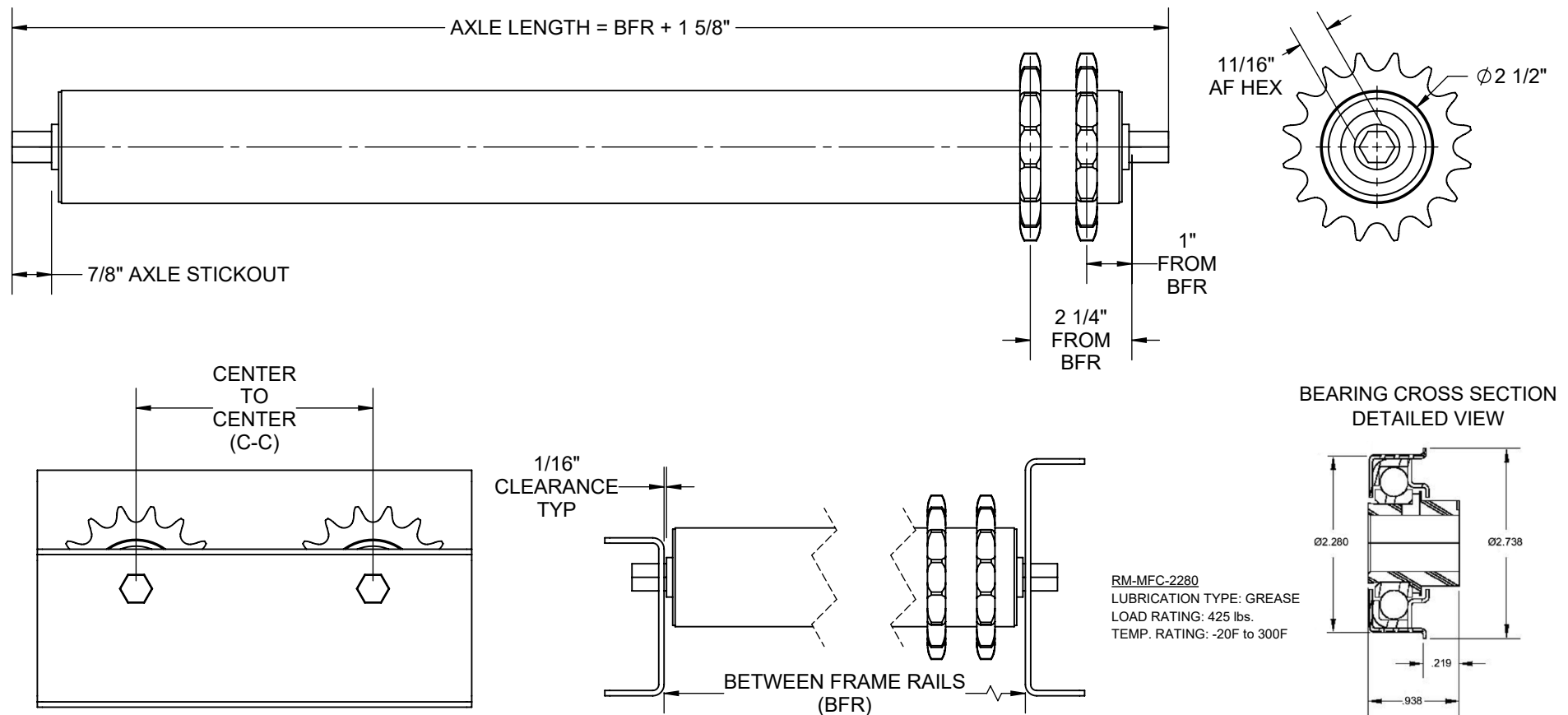

REV

0

Model: CR2511C - 60A16X2.5

