

SPECIFICATIONS	
OVERALL LENGTH	12" TO 120"
OVERALL WIDTH	3 13/16"
WHEEL CENTERS	3"
BETWEEN FRAME RAILS	13/16"
WHEELS	1.9" DIA X 1/4" BORE - ZINC PLATED STEEL
BEARINGS TYPE	NON-PRECISION, OILED
SIDE CHANNELS	2 1/2" X 1 1/2" X 12 GA
FRAME MATERIAL	PLAIN STEEL
FINISH	INDUSTRIAL ENAMEL
OPERATING TEMP. RANGE	150F TO 350F

NOTE:

\*OVERALL LENGTH MUST BE DIVISIBLE BY C-C.

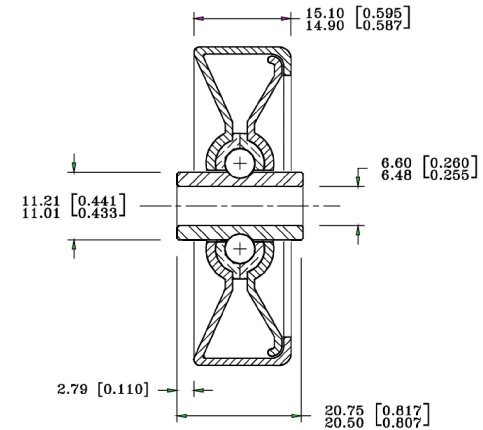
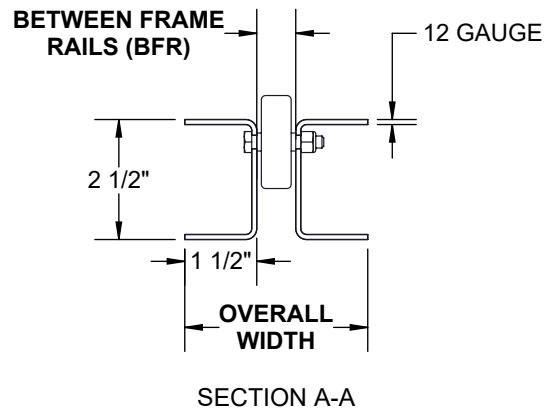
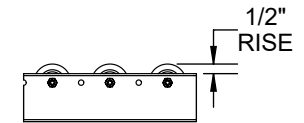
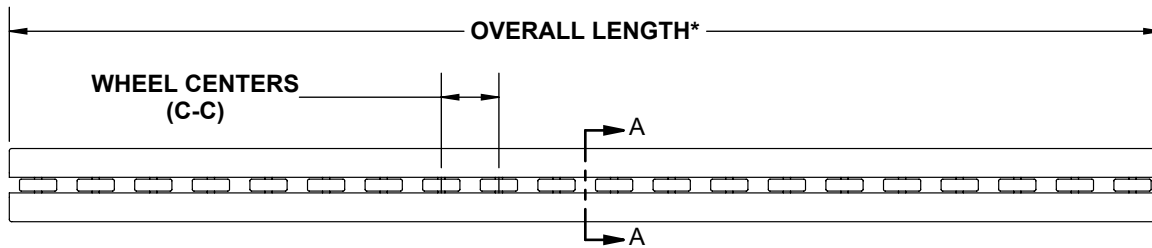
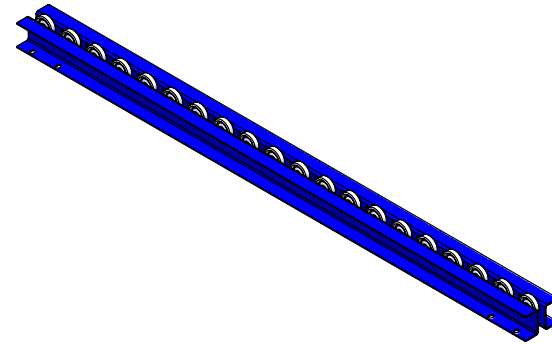

RM-SW2000 / SKATE WHEEL  
 LUBRICATION TYPE: OIL  
 LOAD RATING: 50 LBS.  
 TEMP. RATING: 10.4F TO 428F